

THE INFORMATION CONTAINED IN THIS DOCUMENT IS PROPRIETARY TO JEN JIA PRECISION TECHNOLOGY COLTD, ANY REPRODUCTION IN PART OR WHOLE WITHOUT PRIOR WRITTEN APPROVAL OR AUTHORIZATION OF JEN JIA PRECISION TECHNOLOGY COLTD IS STRICTLY PROHIBITED.

RoHS COMPLIANT

REVISIONS				
REV	ECN NO.	DESCRIPTION	APPROVED BY	DATE
A		NEW DRAWING	JASON MENG	2005-08-01

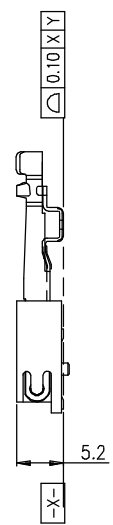
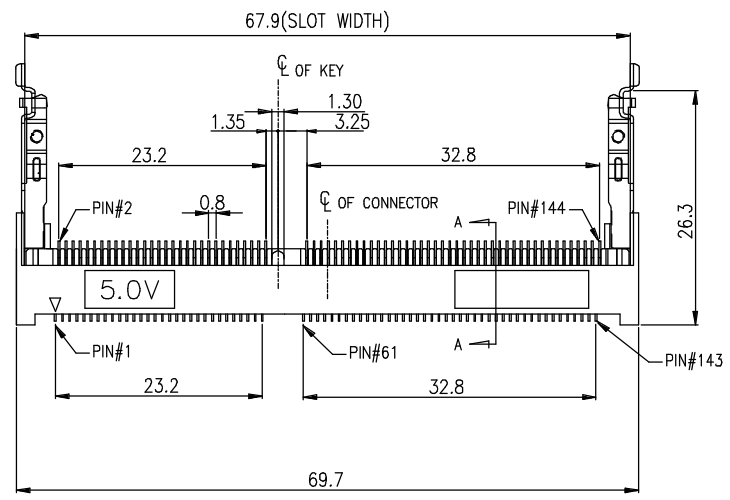
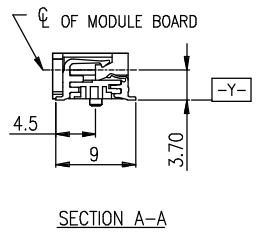
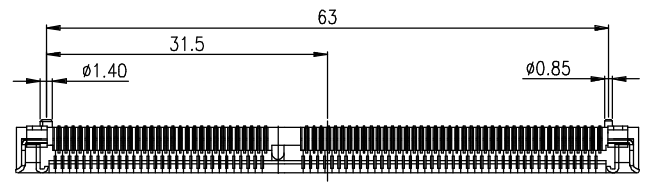

- * MATERIAL :
HOUSING : THERMOPLASTIC,LCP UL94V-0.
CONTACT : PHOSPHOR BRONZE OR BRONZE.
METAL SPRING & SOLDER PAD: SUS301.
- * FINISH :
HOUSING : IVORY COLOR.
CONTACT : AU SELECTIVE PLATED ,50u" MIN. NICKEL UNDER PLATING,100u" MIN. SN ONLY PLATED AT TAIL.
- * CHARACTERISTICS :
CURRENT RATING : 0.3 AMPERE MAX.
VOLTAGE RATING : 25 VAC.
OPERATION TEMPERATURE : -55°C TO +85°C.
DURABILITY : 30 MATING CYCLES.
CONTACT RETENTION FORCE : 0.15 KGF MIN PER PIN.
CONTACT RESISTANCE : 35 MILLIOHMS MAX. INITIAL.
INSULATION RESISTANCE : 250 MEGAOHMS MIN.
DIELECTRIC WITHSTANDING VOLTAGE : 250VAC RMS AT 60HZ, FOR 1 MINUTE.

DO NOT SCALE DRAWING

DIMENSIONS:

MM [INCH] INCH [MM] MM ONLY

UNLESS OTHERWISE SPECIFIED, GENERAL TOLERANCE:

DECIMALS	ANGLES
X. ±0.38 [0.015]	X* ±3°
.X ±0.25 [0.010]	.X* ±1.0°
.XX ±0.13 [0.005]	

CAD GENERATED DRAWING, DO NOT MANUALLY UPDATE

THIRD ANGLE PROJECTION

JJP Jen Jia Precision Technology Co., Ltd.			
TITLE	S.O DIMM 144 POS SMT 5.2MM(RoHS)		
PART NO.	J19154-144-F7A110N	APPROVED BY	JASON MENG
DRAWING NO.	J19154-144-F7A110N	CHECKED BY	STEVEN LIU
MATERIAL		DRAWN BY	Darren Xia
FINISH		GENERATD DATE	2005-08-01
SCALE	SHEET	REV.	SIZE: A4
FREE	1/2	A	FILE NO.:JJP-A-05-003

THE INFORMATION CONTAINED IN THIS DOCUMENT IS PROPRIETARY TO JEN JIA PRECISION TECHNOLOGY CO.LTD, ANY REPRODUCTION IN PART OR WHOLE WITHOUT PRIOR WRITTEN APPROVAL OR AUTHORIZATION OF JEN JIA PRECISION TECHNOLOGY CO.LTD IS STRICTLY PROHIBITED.

RoHS COMPLIANT

REVISIONS

REV	ECN NO.	DESCRIPTION	APPROVED BY	DATE
A		NEW DRAWING	JASON MENG	2005-08-01

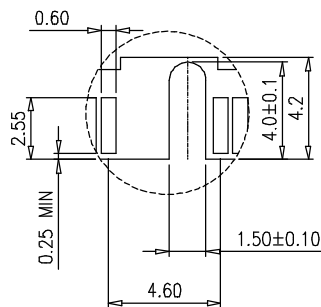
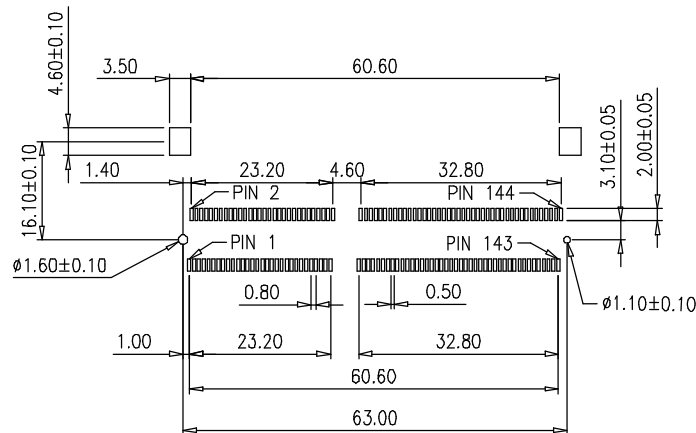
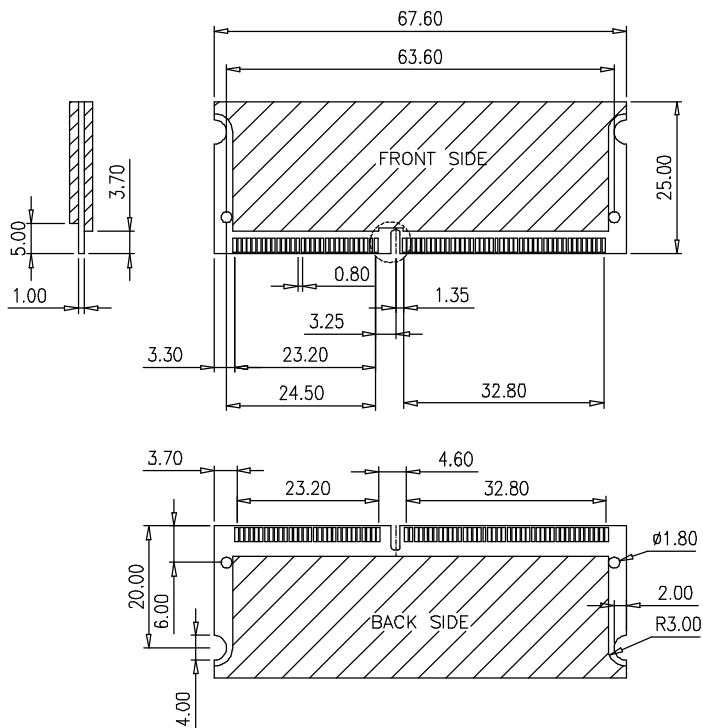

RECOMMEND PCB LAYOUT MODULE AND PATTERN

DO NOT SCALE DRAWING

DIMENSIONS:

MM [INCH] INCH [MM] MM ONLY

UNLESS OTHERWISE SPECIFIED, GENERAL TOLERANCE:

DECIMALS	ANGLES
X. ±0.38 [0.015]	X° ±3°
.X ±0.25 [0.010]	.X° ±1.0°
.XX ±0.13 [0.005]	

CAD GENERATED DRAWING, DO NOT MANUALLY UPDATE

THIRD ANGLE PROJECTION

JJP Jen Jia Precision Technology Co., Ltd.			
TITLE	S.O DIMM 144 POS SMT 5.2MM(RoHS)		
PART NO.	J19154-144-F7A110N	APPROVED BY	JASON MENG
DRAWING NO.	J19154-144-F7A110N	CHECKED BY	STEVEN LIU
MATERIAL		DRAWN BY	Darren Xia
FINISH		GENERATD DATE	2005-08-01
SCALE	SHEET	REV.	SIZE: A4
FREE	2/2	A	FILE NO.:JJP-A-05-003