

THE INFORMATION CONTAINED IN THIS DOCUMENT IS PROPRIETARY TO JEN JIA PRECISION TECHNOLOGY CO.LTD. ANY REPRODUCTION IN PART OR WHOLE WITHOUT PRIOR WRITTEN APPROVAL OR AUTHORIZATION OF JEN JIA PRECISION TECHNOLOGY CO.LTD IS STRICTLY PROHIBITED.

Halogen Free

REVISIONS

| REV | ECN NO. | DESCRIPTION      | APPROVED BY | DATE       |
|-----|---------|------------------|-------------|------------|
| 1   |         | PROPOSAL DRAWING | JASON MENG  | 2013-07-24 |

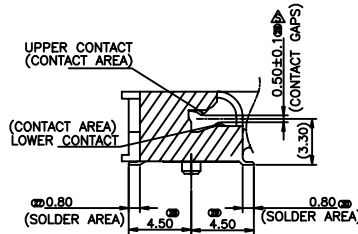
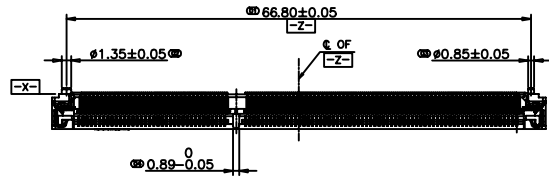

SECTION A-A  
SCALE 2:1

NOTES:

- MATERIAL:
  - HOUSING: HIGH TEMPERATURE THERMOPLASTIC, UL94V-0; COLOR: BLACK.
  - CONTACTS: COPPER ALLOY
  - LATCH: STAINLESS STEEL
  - FLOATING PEG: STAINLESS STEEL
- FINISH:
  - CONTACT: GOLD (SEE TABLE) PLATED ON CONTACT AREA AND GOLD 2u" SOLDER AREA. 50u" MIN. NICKEL UNDERPLATING.
  - FLOATING PEG: GOLD FLASH PLATED ON SOLDERING AREA. 50u" MIN. NICKEL UNDERPLATING.
- REFLOW SOLDER CAPABLE TO 260°C.
- SHOULD BE MEASURED BY CPK
- MAKED "M" DIMENSIONS NEED BE CONTROLLED IN FAI.

PART NUMBER:

J4319-204 X X X HF 44

- HF: HALOGEN FREE
- PACKAGE CODE:
  - R: TAPE & REEL PACKING
  - T: TRAY PACKING
- PLATING CODE:
  - 1: GOLD FLASH 4: Au15u"
  - 2: Au5u" 5: Au20u"
  - 3: Au10u" 6: Au30u"
- MARK & HSG COLOR:
  - 0: DDR3 STD 1.5V & BLACK
  - 1: DDR3 STD & BLACK 2: STD & BLACK
  - 3: DDR3 STD 1.5V & IVORY
  - 4: DDR3 STD & IVORY 5: STD & IVORY
- PIN NUMBER CODE:
  - 204: 204 PINS

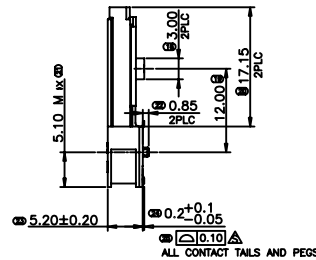
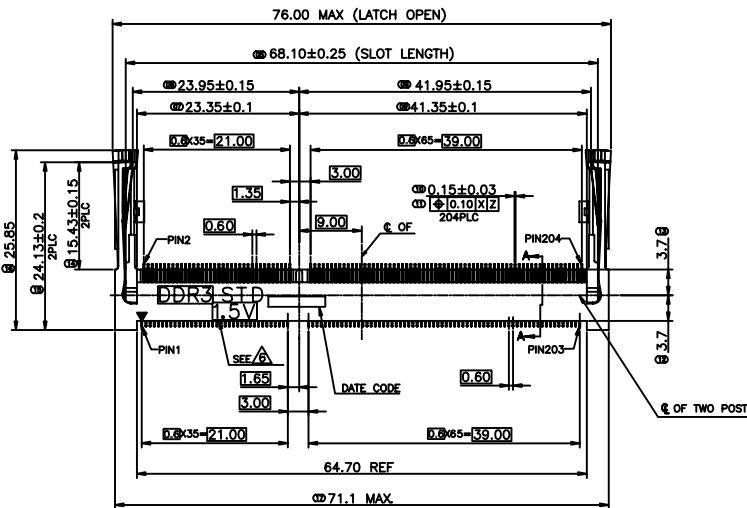

ALL CONTACT TAILS AND PEGS

TABLE

| NUMBER           | PLATED(TERMINAL) |
|------------------|------------------|
| J4319-204X6XHF44 | Au 30u"          |
| J4319-204X5XHF44 | Au 20u"          |
| J4319-204X4XHF44 | Au 15u"          |
| J4319-204X3XHF44 | Au 10u"          |
| J4319-204X2XHF44 | Au 5u"           |
| J4319-204X1XHF44 | GOLD FLASH       |
| UNMBER           | PLATED(TERMINAL) |

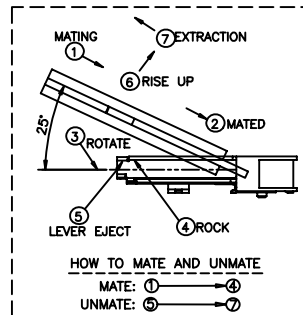

DIMENSIONS:  
 MM [INCH]  INCH [MM]  MM ONLY

UNLESS OTHERWISE SPECIFIED, GENERAL TOLERANCE:

DECIMALS ANGLES  
 X. ±0.38 [0.015] X° ±2°  
 .X ±0.25 [0.010] .X° ±1.0°  
 .XX ±0.15 [0.006]

CAD GENERATED DRAWING, DO NOT MANUALLY UPDATE

THIRD ANGLE PROJECTION

JJP Jen Jia Precision Technology Co., Ltd.

| TITLE       |                  | DDRIII SO DIMM 5.2H STD ASS'Y |                       |
|-------------|------------------|-------------------------------|-----------------------|
| PART NO.    | J4319-204XXXHF44 | APPROVED BY                   | JASON MENG            |
| DRAWING NO. | J4319-204XXXHF44 | CHECKED BY                    | STEVEN LIU            |
| MATERIAL    |                  | DRAWN BY                      | Darren Xia            |
| FINISH      |                  | GENERATD DATE                 | 2013-07-24            |
| SCALE       | SHEET            | REV.                          | SIZE: A4              |
| FREE        | 1/5              | 1                             | FILE NO.:JJP-A-05-003 |

DO NOT SCALE DRAWING

THE INFORMATION CONTAINED IN THIS DOCUMENT IS PROPRIETARY TO JEN JIA PRECISION TECHNOLOGY CO.,LTD. ANY REPRODUCTION IN PART OR WHOLE WITHOUT PRIOR WRITTEN APPROVAL OR AUTHORIZATION OF JEN JIA PRECISION TECHNOLOGY CO.,LTD IS STRICTLY PROHIBITED.

Halogen Free

REVISIONS

| REV | ECN NO. | DESCRIPTION      | APPROVED BY | DATE       |
|-----|---------|------------------|-------------|------------|
| 1   |         | PROPOSAL DRAWING | JASON MENG  | 2013-07-24 |

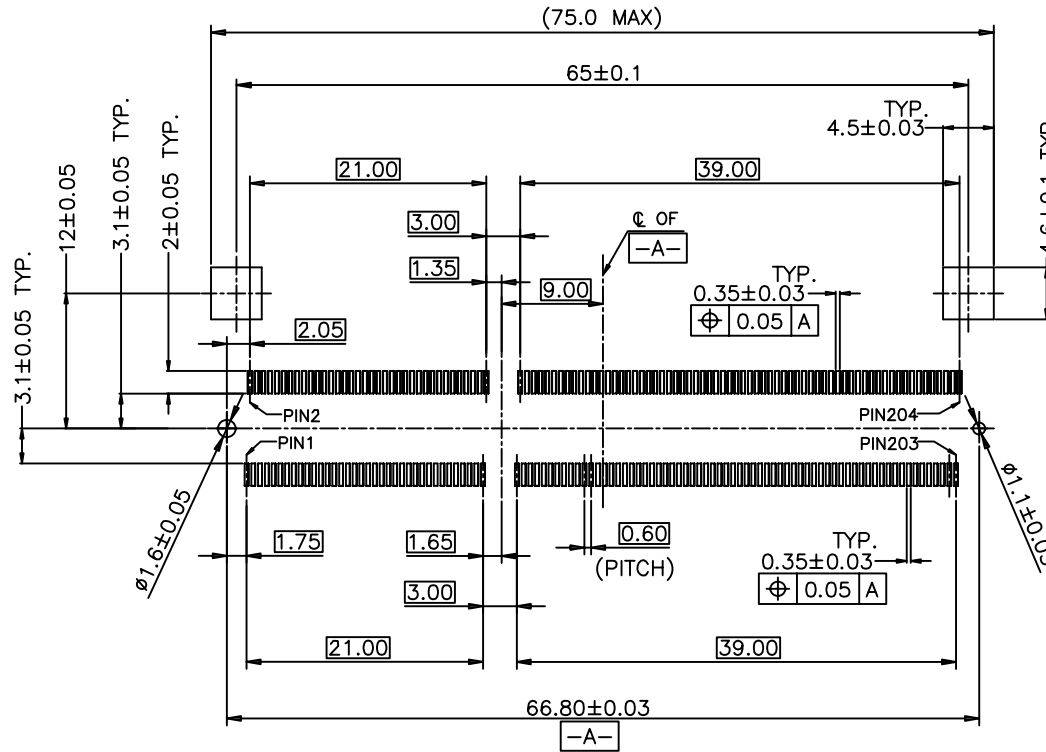

RECOMMENDED PCB LAYOUT

STANDARD TYPE

DO NOT SCALE DRAWING

DIMENSIONS:  
 MM [INCH]    INCH [MM]    MM ONLY  
 UNLESS OTHERWISE SPECIFIED,  
 GENERAL TOLERANCE:  
 DECIMALS      ANGLES  
 X. ±0.38 [0.015]   X° ±2°  
 .X ±0.25 [0.010]   .X° ±1.0°  
 .XX ±0.15 [0.006]

CAD GENERATED DRAWING,  
 DO NOT MANUALLY UPDATE

THIRD ANGLE PROJECTION



**JJP** Jen Jia Precision Technology Co., Ltd.

|             |                 |                               |                       |
|-------------|-----------------|-------------------------------|-----------------------|
| TITLE       |                 | DDRIII SO DIMM 5.2H STD ASS'Y |                       |
| PART NO.    | J4319-204XXHF44 | APPROVED BY                   | JASON MENG            |
| DRAWING NO. | J4319-204XXHF44 | CHECKED BY                    | STEVEN LIU            |
| MATERIAL    |                 | DRAWN BY                      | Darren Xia            |
| FINISH      |                 | GENERATD DATE                 | 2013-07-24            |
| SCALE       | SHEET           | REV.                          | SIZE: A4              |
| FREE        | 2/5             | 1                             | FILE NO.:JJP-A-05-003 |

THE INFORMATION CONTAINED IN THIS DOCUMENT IS PROPRIETARY TO JEN JIA PRECISION TECHNOLOGY CO.LTD. ANY REPRODUCTION IN PART OR WHOLE WITHOUT PRIOR WRITTEN APPROVAL OR AUTHORIZATION OF JEN JIA PRECISION TECHNOLOGY CO.LTD IS STRICTLY PROHIBITED.

Halogen Free

REVISIONS

| REV | ECN NO. | DESCRIPTION      | APPROVED BY | DATE       |
|-----|---------|------------------|-------------|------------|
| 1   |         | PROPOSAL DRAWING | JASON MENG  | 2013-07-24 |

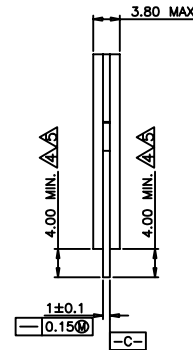
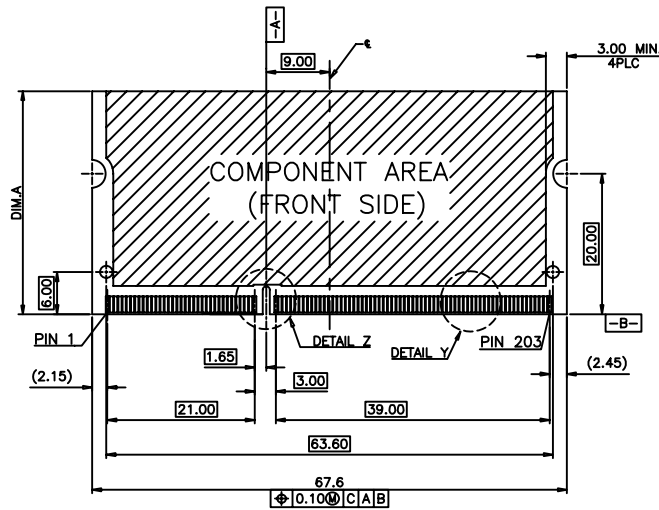

- NOTE:
- TOLERANCES ON ALL DIMENSIONS  $\pm 0.15$  UNLESS OTHERWISE SPECIFIED.
  - P.C.BOARD THICKNESS APPLIES ACROSS TABS AND INCLUDES PLATING AND/OR MENTAIZATION.
  - FINISH OF PAD:GOLD PLATING 0.00076MIN OVER ON PLATING 0.002MIN.
  - DIMENSIONS APPLICABLE WHEN COMPONENTS MOUNTED ON BOTH SIDE. PCB THICKNESS NOT TO BE EXCEEDED OUTSIDE OF COMPONENT AREA.
  - BORDER OF COMPONENT AREA.
  - REFER TO JEDEC SPEC. MO-268 FOR COMPLETE MODULE.

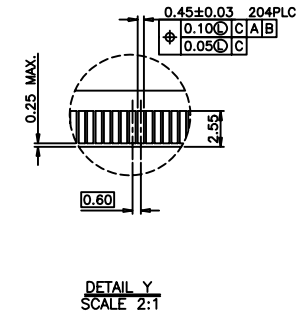
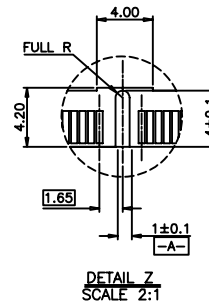
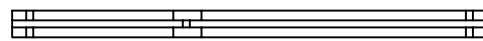

|        |                  |
|--------|------------------|
| 30.00  | CA               |
| 31.75  | BA               |
| 25.40  | AA               |
| DIM. A | SDRAM VARIATIONS |

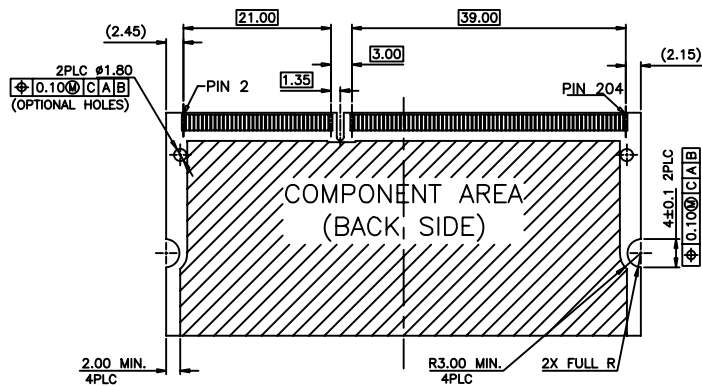

RECOMMENDED MATING P.C.B CONFIGURATION

DIMENSIONS:  
 MM [INCH]  INCH [MM]  MM ONLY  
 UNLESS OTHERWISE SPECIFIED, GENERAL TOLERANCE:  
 DECIMALS ANGLES  
 X.  $\pm 0.38$  [0.015] X\*  $\pm 2^\circ$   
 .X  $\pm 0.25$  [0.010] .X\*  $\pm 1.0^\circ$   
 .XX  $\pm 0.15$  [0.006]

JJP Jen Jia Precision Technology Co., Ltd.

TITLE DDRIII SO DIMM 5.2H STD ASS'Y

PART NO. J4319-204XXHF44 APPROVED BY JASON MENG

DRAWING NO. J4319-204XXHF44 CHECKED BY STEVEN LIU

MATERIAL DRAWN BY Darren Xia

FINISH GENERATD DATE 2013-07-24

SCALE FREE SHEET 3/5 REV. 1 SIZE: A4  
 FILE NO.:JJP-A-05-003

DO NOT SCALE DRAWING

THE INFORMATION CONTAINED IN THIS DOCUMENT IS PROPRIETARY TO JEN JIA PRECISION TECHNOLOGY CO.,LTD. ANY REPRODUCTION IN PART OR WHOLE WITHOUT PRIOR WRITTEN APPROVAL OR AUTHORIZATION OF JEN JIA PRECISION TECHNOLOGY CO.,LTD IS STRICTLY PROHIBITED.

Halogen Free

REVISIONS

| REV | ECN NO. | DESCRIPTION      | APPROVED BY | DATE       |
|-----|---------|------------------|-------------|------------|
| 1   |         | PROPOSAL DRAWING | JASON MENG  | 2013-07-24 |

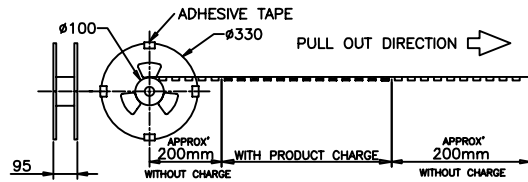

- NOTES : (FOR TAPE & REEL)  
 PACKAGING MATERIAL IN PLASTIC, RUBBER, INK, PIGMENT AND PAINT MUST MEET RoHS CONTROLLED SUBSTANCES SPEC.  
 \* CADMIUM AND CADMIUM COMPOUNDS NOT TO EXCEED:5 PPM.  
 \* LEAD, CADMIUM, CHROM VI AND MERCURY NOT TO EXCEED: 100 PPM (COMBINED).  
 \* CARRIER TAPES, COVER TAPES, REELS AND TAPED COMPONENTS MUST MEET THE REQUIREMENTS DEFINED PER EIA-481-B.
- MATERIAL :  
 COVER TAPE : ANTISTATIC P.S, COLOR: TRANSPARENT.  
 CARRIER TAPE : HIPS, COLOR: BLACK.  
 REEL : PS, COLOR: BLUE.  
 CARTON: CORRUGATED FIBER.
  - QUANTITY : SEE TABLE
  - WEIGHT : SEE TABLE
  - PEELING RESISTANCE : 10gf~150gf (for 88mm)
  - PEELING SPEED : 300mm/MINUTES

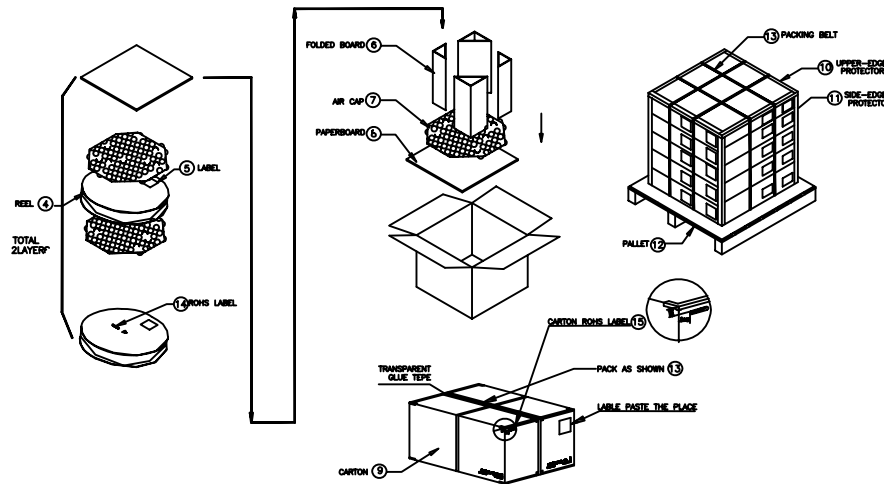
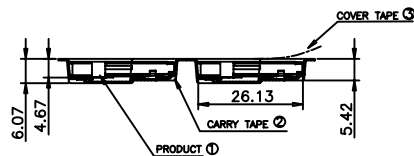
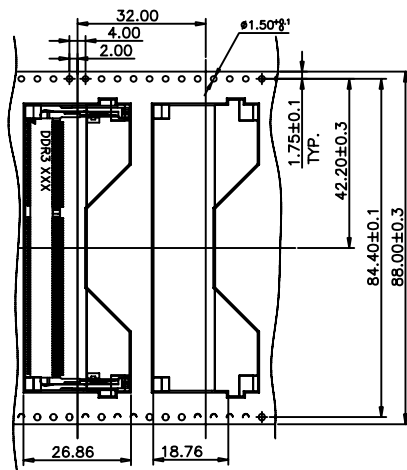

DO NOT SCALE DRAWING

DIMENSIONS:  
 MM [INCH]  INCH [MM]  MM ONLY  
 UNLESS OTHERWISE SPECIFIED, GENERAL TOLERANCE:  
 DECIMALS ANGLES  
 X. ±0.38 [0.015] X° ±2°  
 .X ±0.25 [0.010] .X° ±1.0°  
 .XX ±0.15 [0.006]

**JJP** Jen Jia Precision Technology Co., Ltd.

|             |   |                |                       |
|-------------|---|----------------|-----------------------|
| TITLE       | DDRIII SO DIMM 5.2H STD ASS'Y (TAPE&REEL PACKING) |                |                       |
| PART NO.    | J4319-204XXHF44                                   | APPROVED BY    | JASON MENG            |
| DRAWING NO. | J4319-204XXHF44                                   | CHECKED BY     | STEVEN LIU            |
| MATERIAL    |   | DRAWN BY       | Darren Xia            |
| FINISH      |   | GENERATED DATE | 2013-07-24            |
| SCALE       | SHEET   | REV.           | SIZE: A4              |
| FREE        | 4/5   | 1              | FILE NO.:JJP-A-05-003 |



THE INFORMATION CONTAINED IN THIS DOCUMENT IS PROPRIETARY TO JEN JIA PRECISION TECHNOLOGY CO.LTD. ANY REPRODUCTION IN PART OR WHOLE WITHOUT PRIOR WRITTEN APPROVAL OR AUTHORIZATION OF JEN JIA PRECISION TECHNOLOGY CO.LTD IS STRICTLY PROHIBITED.

Halogen Free

REVISIONS

| REV | ECN NO. | DESCRIPTION      | APPROVED BY | DATE       |
|-----|---------|------------------|-------------|------------|
| 1   |         | PROPOSAL DRAWING | JASON MENG  | 2013-07-24 |

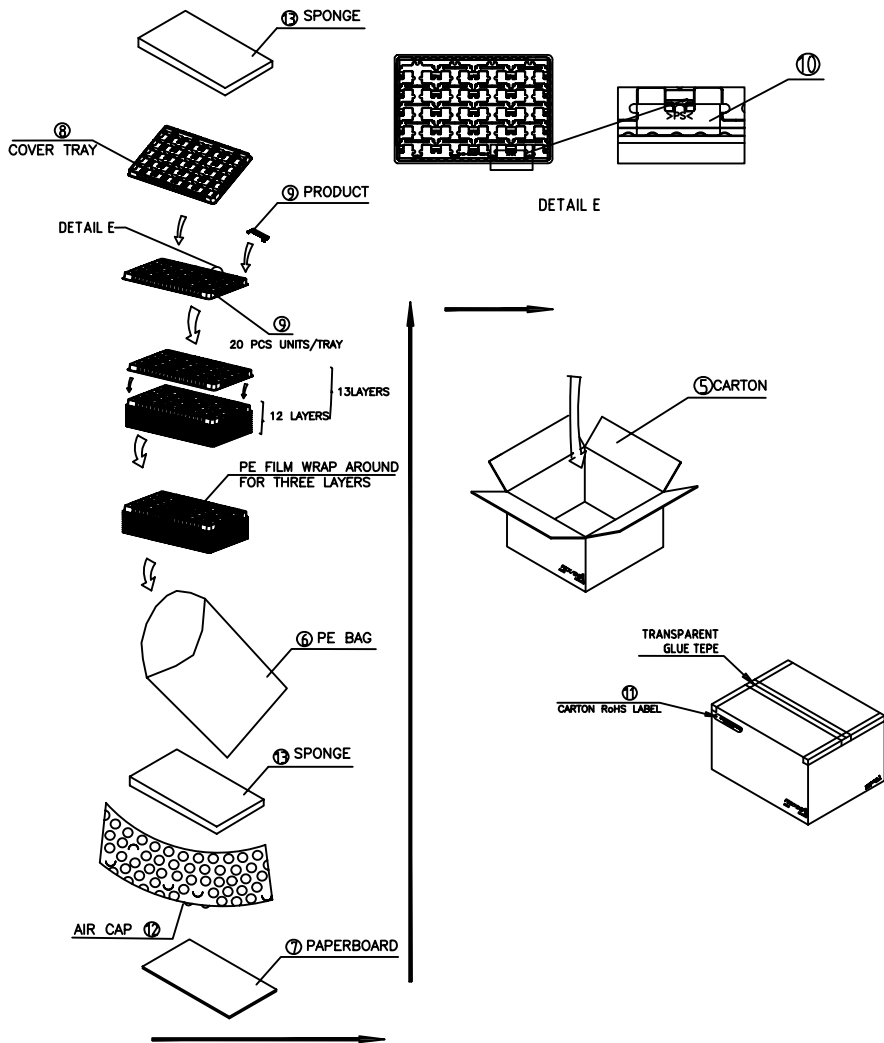

- NOTES : (FOR TRAY)  
 PACKAGING MATERIAL IN PLASTIC, RUBBER, INK, PIGMENT AND PAINT MUST MEET RoHS CONTROLLED SUBSTANCES SPEC.  
 \* CADMIUM AND CADMIUM COMPOUNDS NOT TO EXCEED:5 PPM.  
 \* LEAD, CADMIUM, CHROM VI AND MERCURY NOT TO EXCEED: 100 PPM (COMBINED).  
 \* CARRIER TAPES, COVER TAPES, REELS AND TAPED COMPONENTS MUST MEET THE REQUIREMENTS DEFINED PER EIA-481-B.
1. MATERIAL :  
 TRAY : PET, COLOR: TRANSPARENT.  
 SPONE : LDPE, COLOR:WHITE.  
 CARTON: CORRUGATED FIBER.
2. QUANTITY : 20PCS/TRAY,240PCS/CARTON.

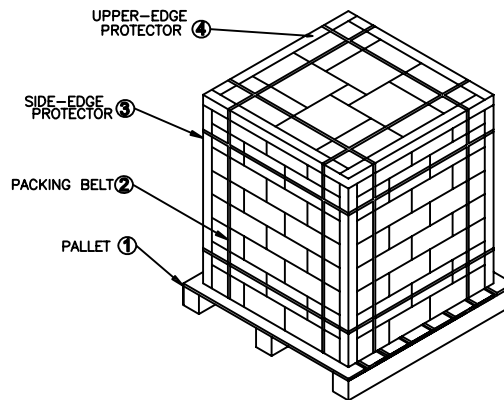

DO NOT SCALE DRAWING

DIMENSIONS:  
 MM [INCH]     INCH [MM]     MM ONLY

UNLESS OTHERWISE SPECIFIED, GENERAL TOLERANCE:  
 DECIMALS                      ANGLES  
 X. ±0.38 [0.015]              X° ±2°  
 .X ±0.25 [0.010]              .X° ±1.0°  
 .XX ±0.15 [0.006]

**JJP** Jen Jia Precision Technology Co., Ltd.

|             |   |               |                       |
|-------------|---|---------------|-----------------------|
| TITLE       | DDRIII SO DIMM 5.2H STD ASS'Y(TRAY PACKING) |               |                       |
| PART NO.    | J4319-204XXHF44                             | APPROVED BY   | JASON MENG            |
| DRAWING NO. | J4319-204XXHF44                             | CHECKED BY    | STEVEN LIU            |
| MATERIAL    |   | DRAWN BY      | Darren Xia            |
| FINISH      |   | GENERATD DATE | 2013-07-24            |
| SCALE       | SHEET                                       | REV.          | SIZE: A4              |
| FREE        | 5/5   | 1             | FILE NO.:JJP-A-05-003 |

